



Section 23

Balancing Valves

Edition 3

Variable Balancing Valve

Variable orifice bronze double regulating valve

Fig. 9505, with test points

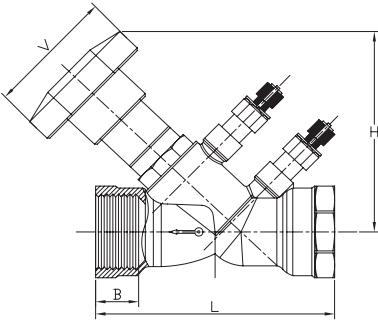

Material List	
PART	MATERIAL
Body	Bronze
Balancing cone	DR Brass
Gasket Disc	PTFE
Disc O-ring	EPDM Perox
Disc Stem	DR Brass
Stem O-ring	EPDM Perox
Union	DR Brass
Stem	Brass
Bonnet	DR Brass
Stop spring ring	Spring Steel
Screw	Screw
Handwheel	ABS (blue)
Nut	Steel
Test point / plug	DR Brass
Tie	Polyprop

Specifications	
Thread F/F	ISO 228
Design	BS7350
Working Pressure	2500kPa up to 80°C
	2000kPa up to 100°C
Working Temperature **	-10°C - 130°C

** Below 0°C only for water with added antifreezing fluids

** Over 100°C only for water with additives avoiding boiling

Variable Balancing Valve							
AAP CODE	IMPERIAL SIZE	H	L	B	V	APPROX. KG/PC	Flow Range (l/s)
BAL15	1/2	90	90	17.5	70	0.5	.062 - .148
BAL20	3/4	90	102	18	70	0.56	.138 - .325
BAL25	1	90	110	19	70	0.7	.258-.603

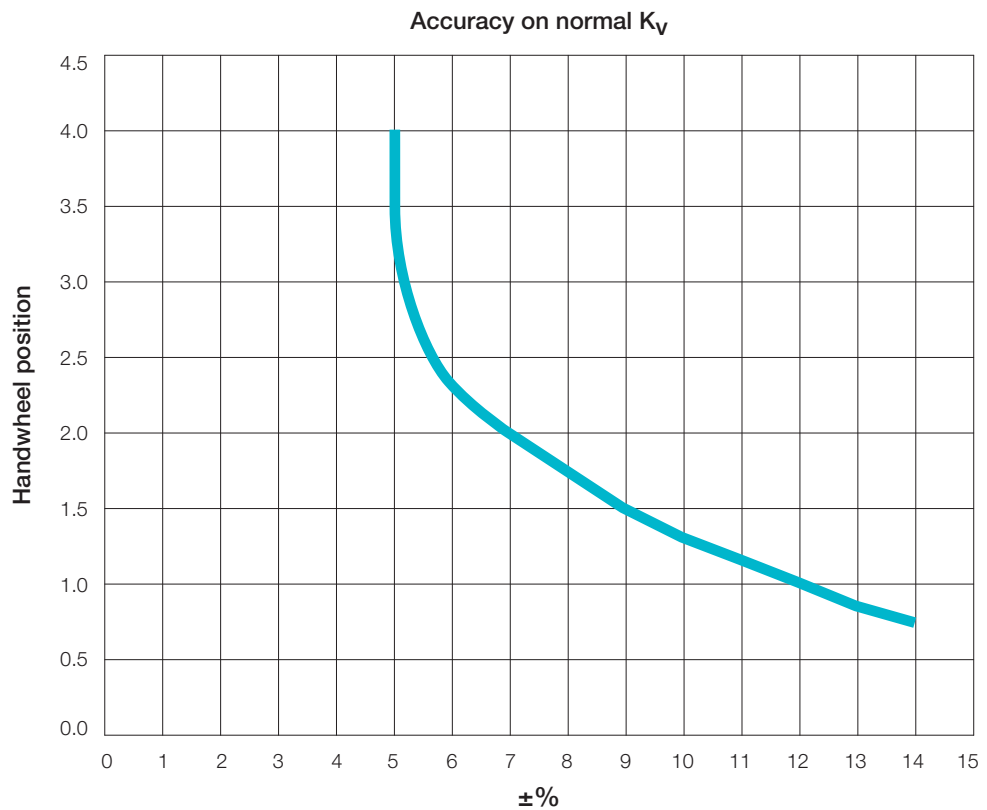

HANDWHEEL POSITION	Flow Measurement		
	Kv (m3/h @ 1bar)		
	15	20	25
0.5	0.37	0.40	1.40
0.6	0.40	0.44	1.58
0.7	0.44	0.50	1.70
0.8	0.47	0.57	1.80
0.9	0.52	0.64	1.89
1	0.55	0.70	2.00
1.1	0.60	0.75	2.12
1.2	0.64	0.77	2.26
1.3	0.68	0.80	2.40
1.4	0.71	0.84	2.50
1.5	0.75	0.90	2.60
1.6	0.78	0.96	2.74
1.7	0.81	1.00	2.90
1.8	0.87	1.07	3.06
1.9	0.91	1.14	3.27
2	0.94	1.20	3.50
2.1	0.97	1.25	3.76
2.2	1.00	1.29	4.03
2.3	1.06	1.30	4.30
2.4	1.10	1.39	4.56
2.5	1.18	1.50	4.80
2.6	1.26	1.57	4.96
2.7	1.35	1.70	5.10
2.8	1.49	1.85	5.24
2.9	1.63	2.02	5.37
3	1.75	2.20	5.50
3.1	1.93	2.43	5.60
3.2	2.08	2.67	5.71
3.3	2.25	2.90	5.80
3.4	2.35	3.15	5.91
3.5	2.44	3.40	6.00
3.6	2.46	3.61	6.10
3.7	2.50	3.80	6.18
3.8	2.55	3.96	6.26
3.9	2.60	4.06	6.34
4	2.67	4.10	6.40

**Tolerance on nominal K for completely open valve is ±5% (test according to BS7350)

Formula linking flow Q (in l/s) and Δp are measured at test points (in kPa). K depends on handwheel position as indicated in the table. Minimum flow that can be measured for each diameter may be calculated by using the formulae minimum Δp that can be measured by using manometer. Valves are designed for best performance when used on a range previously suggested and as indicated by BS7350

$$Q = \frac{K_v \cdot \sqrt{\Delta p \cdot TP}}{36}$$

